

DS33Z11 - Ethernet LAN To Unframed T1/E1 WAN Bridge

In today's data-intensive society, the line between Wide Area Networks (WAN) and Local Area Networks (LAN) is starting to fade. Telecom providers traditionally offer customers a WAN connection through T1, E1, or higher speed mediums such as fiber. The typical LAN, however, is created through the use of Ethernet connections on the customer's premises. To bridge the WAN and LAN, a customer typically must purchase multiple pieces of equipment or a multiprotocol system which provide a common connection between the two networks. To ease the bridging of the WAN and LAN, Dallas Semiconductor created the ELITE (Ethernet Link Transport Engine) product line. This application note presents a design based on the ELITE product line and demonstrates the use of a DS33Z11 to bridge Ethernet traffic over an unframed T1 or E1 connection. By using an unframed WAN link, the design is kept simple, cost minimized, and the data rate maximized.

Design

When designing equipment for telecommunication use, it is important that the integrity of the interconnected data signals be maintained for error-free operation. The board should have a separate power and ground plane, and the power supply should be decoupled to reduce noise.

The main component of the LAN-to-WAN bridge is the Dallas Semiconductor Elite product line, specifically the DS33Z11, a single-port 10/100 Ethernet-to-serial interface. The device bridges an Ethernet connection and a serial connection (also known as a WAN connection), such as T1, E1, T3, E3, or HDSL. The device is composed of a 10/100 Ethernet MAC, Packet Arbiter, Committed Information Rate controller, HDLC/X.86 Mapper, SDRAM interface, Bit Error Rate Tester (BERT), and control logic.

The Elite line of devices performs two tasks. First, the DS33Z11 encapsulates the LAN Ethernet traffic with HDLC or X.86 (LAPS) for transmission over the WAN interface. Secondly, the DS33Z11 extracts encapsulated Ethernet packets received from the WAN interface for transmission over the LAN interface. The DS33Z11 can be configured by interfacing to a microcontroller which allows interactive control, by using a serial EEPROM which allows easy one-time power-up configuration, or by directly biasing the hardware pins which allows operation with no external components.

The physical connection to the WAN is provided by the Dallas Semiconductor DS21348 T1/E1/J1 single-port line interface. The DS21348 performs all the functions necessary for interfacing at the physical layer to a T1, E1, or J1 line. The receiver performs clock and data recovery, signal

decoding, and loss-of-signal monitoring. The transmitter performs signal encoding and drives standard-compliant waveforms onto 100ohm or 120ohm unshielded, twisted-pair cable or 75ohm coaxial cable. A built-in jitter attenuator can be mapped into the receive or transmit path.

The physical connection to the LAN is provided by the National Semiconductor DP83846A single-port 10/100 Ethernet transceiver. This transceiver, also known as a Physical Layer device (PHY), supports both 10Base-T and 100Base-TX Ethernet protocols over Category 3 or Category 5 unshielded twisted-pair cable. Digital-signal-processor technology and digital phase-lock loops are used in the transmit and receive circuitry. This results in enhanced performance, better noise immunity, and fewer external components.

The remaining components are comprised of the microcontroller and associated circuitry, 128Mbit Synchronous Dynamic RAM (SDRAM), crystal oscillators, transformers, RJ-45 connectors, resistors, capacitors, and an external or on-board 3.3V power supply. Figure 1 and Table 1 show all the components necessary to build the LAN-to-WAN bridge, excluding the power supply.

The circuit is straightforward with the DS33Z11 connected to the DS21348 on the WAN side and to the DP83846A on the LAN side. The DS21348 interfaces directly to the DS33Z11 through the transmit and receive serial and clock connections. The DP83846A interfaces directly to the DS33Z11 through the IEEE 802.3 Media Independent Interface (MII) connections. The configuration of the DS33Z11, DS21348, and DP83846A is performed by the microcontroller. However, if cost is a factor and reconfiguration of the devices not an issue, all the devices support configuration without using a microcontroller. While the DS33Z11 may need an external EEPROM to support certain hardware-only configurations, the DS21348 and DP83846A are configured through preset voltages present on external pins. The 25MHz oscillator is needed for the Ethernet interface and the 1.544MHz or 2.048MHz oscillator is needed for the T1 or E1 interface. If the DS21348 recovered clock also drives the transmit clock, it is possible to use the internal PLL to operate in T1 or E1 mode with only a 2.048MHz oscillator. Because every application is slightly different, the remaining circuit connections are left to the designer. For further assistance with the device, please use the links found in the References section below.

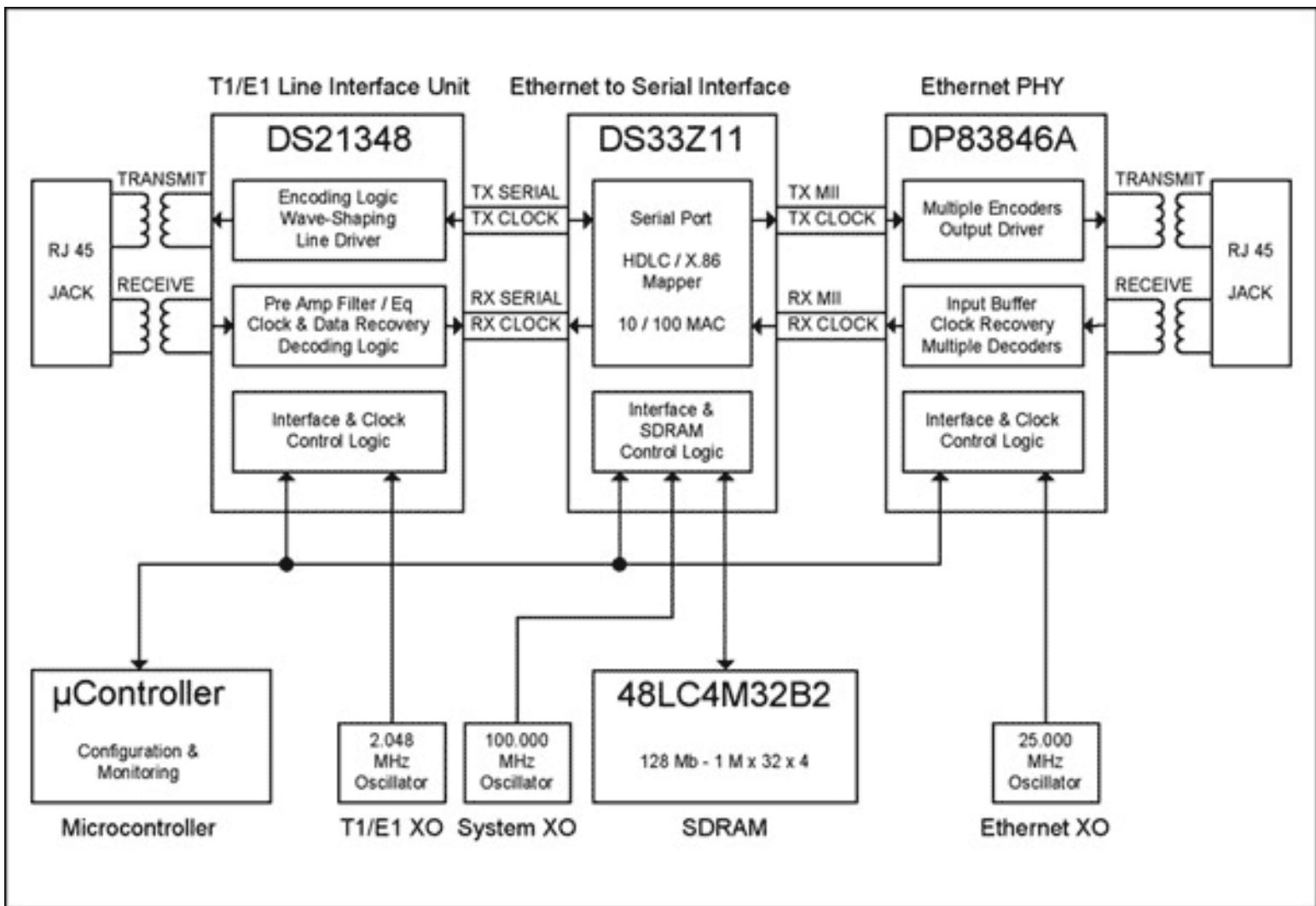

Figure 1. Block Diagram of the Ethernet LAN to Unframed, T1/E1 WAN Bridge

Table 1. Part Listing of the Ethernet LAN to Unframed, T1/E1 WAN Bridge

Device	Part Count	Description	Vendor
DS33Z11	1	3.3V/1.8V single-port Ethernet-to-serial interface	Dallas Semiconductor
DS21348	1	3.3V single-port T1/E1 line interface unit (LIU)	Dallas Semiconductor
DP83846A	1	3.3V single-port 10/100 Ethernet transceiver	National Semiconductor
MT48LCM32B2	1	3.3V 128Mbit SDRAM	Micron Technology
Microcontroller	1	3.3V 8- or 16-bit microcontroller	Various
NTH089AA3-25.0000	1	25.000MHz oscillator, 3.3V	Saronix
NTH089AA3-1.5440	1	1.544MHz oscillator, 3.3V	Saronix
NTH089AA3-2.0480	1	2.048MHz oscillator, 3.3V	Saronix

H1012B or PE-68515L	1	16-pin SMT 1:1CT 10/100Base-T transformer	Pulse Engineering
TX1099	1	16-pin SMT multitap transformer	Pulse Engineering
RJ-45 Jack	2	8-Pin RJ-45 right-angle jack	Various
Power supply/connector	1	Power-supply circuitry	Various
Resistor		Pull-up and bias resistors	Various
Capacitor		Power and decoupling capacitors	Various
LED		Power, LAN, and WAN connection indication	Various

References

For further questions on the LAN-to-WAN bridge design, please contact the Telecommunication Applications support team by email, telecom.support@dalsemi.com, or telephone at 972-371-6555.

More Information

DS33Z11: [QuickView](#) -- [Full \(PDF\) Data Sheet](#)

DS33Z44: [QuickView](#) -- [Full \(PDF\) Data Sheet](#) -- [Free Samples](#)